



# SmartMod+ Digital Input/Output Module

## HE399DIQ522

### 8 Digital Inputs 4 Relay Outputs



#### 1 Specifications

<b>Input Channels</b>	8	<b>Relay Channels</b>	4
<b>Voltage Input (bipolar)</b>	OFF state 0/3 V ON state 10/30 V	<b>Type</b>	SPDT
<b>Input Impedance</b>	4.7 KΩ	<b>Switching Power</b>	2 A @ 250Vac 2 A @ 30Vdc (Resistive load per contact)
<b>Sample Time (per channel)</b>	5ms	<b>Min. Load Max Volt</b>	5Vdc, 10 mA 250 Vac, 30 Vdc
<b>Mounting</b>	DIN Rail standard EN-50022	<b>Dielectric Strength between contacts</b>	1000 Vac, 50Hz, 1min.
<b>Relative Humidity</b>	0 to 90% Non-condensing	<b>Dielectric Strength between coil and contact</b>	4000 Vac, 50 Hz, 1 min
<b># of Counters length</b>	4 32 bit	<b>Frequency Min. Pulse Width</b>	Up to 300 Hz 1 ms
<b>Network Interface</b>	Ethernet 10/100 Base-T	<b>Protocol</b>	Modbus TCP
<b>Max Cable Length</b>	100 meters	<b>Number of socket</b>	Up to 16
<b>Operating Temp.</b>	-10° to 60 °C	<b>Storage Temp.</b>	-40 – 85 °C
<b>External Power Supply Voltage</b>	10-30Vdc	<b>Weight</b>	~160g
<b>Power Consump.</b>	Standby – 60 mA tip@24Vdc Operative – 90mA max@24Vdc Operative – 220 mA@10Vdc	<b>Connections</b>	Ethernet, RJ45, Removable screw-terminals
<b>Reverse Polarity Protection</b>	60 Vdc max	<b>Max. Data Transmission Baud Rate</b>	115.2 Kbps
<b>Isolation</b>	1500 Vac, 50Hz, 1 min	<b>Max. Distance</b>	1200m
<b>CE Compliance</b>	Immunity EN 61000-6-2 Emission EN 61000-6-4		

#### Mechanical Dimensions (mm)

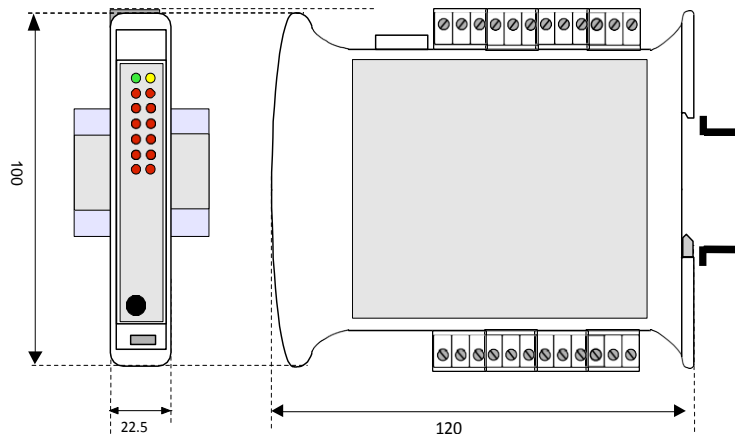

Note: Number of I/O terminal connections varies from model to model

#### CONNECTIONS

#### Relay Outputs

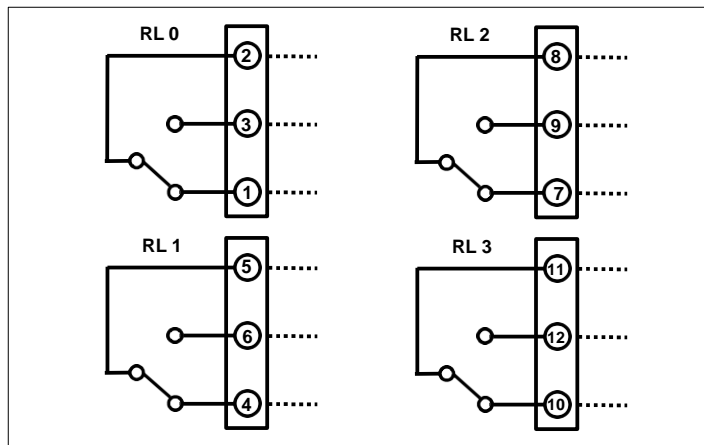

#### 2 Connections

##### Digital Inputs

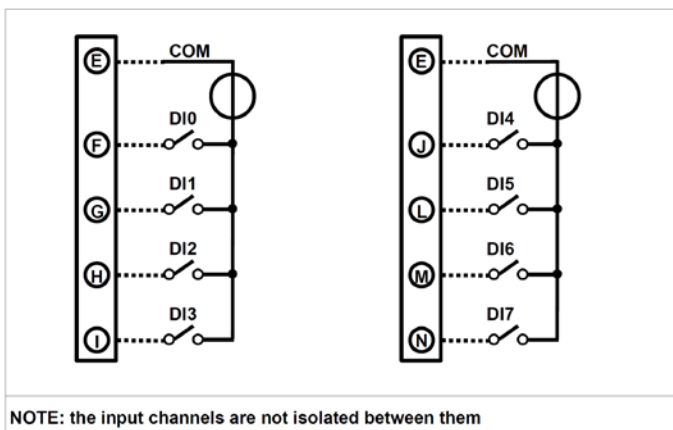

##### Power Supply

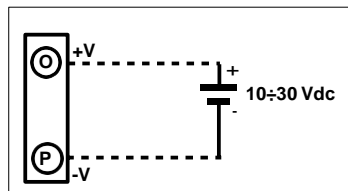

##### INIT

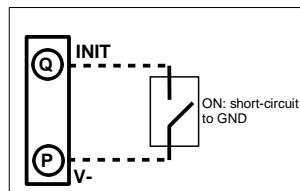

### 3 Communication Protocols

The module is designed to work with the MODBUS TCP/IP protocol. The Ethernet interface allows the values of the modules internal registers to be written and read in real time, and allows the direct interface of HE399 series modules to all Horner Ethernet based X-Series controllers.

### 4 User Instructions

Before installing this module, please read the **Installation Instructions** section carefully. To configure the module using the INIT mode: Connect the terminal INIT to the terminal -V, at power-on the module will automatically set to the configuration set-up. Connect the power supply, serial bus, inputs and outputs as shown in the **Wiring** section. The LEDs state depends on the working condition of the module, see the **LED Indicator** section to verify the modules working state. To perform configuration and calibration operations, read the instructions below.

To simplify handling or replacing the module, it is possible to remove the wired terminals when the module is powered on.

### 5 Installation Instructions

Attach the HE399DIQ522 to DIN rails in the vertical position. For optimum operation follow these instructions:

**When the modules are installed side by side and** - If the panel temperature exceeds 45°C and power supply voltage is 10 VDC - **it may be necessary to separate them by >5 mm:**

Make sure that there is sufficient air flow around the module, avoid placing near cable routing or other objects that can obstruct the ventilation slits. Additionally, avoid mounting modules above appliances that generate heat. Ideally, they should be placed in the lower part of the panel. Install the module in a location without vibration.

It is also recommended to avoid routing conductors near power signal cables (motors, induction ovens, inverters etc...) and to use shielded cables for connecting signals.

### 6 LED Indicator

LED	COLOUR	STATE	DESCRIPTION
PWR	GREEN	ON	Device powered
		OFF	Device not powered
		BLINK	Watchdog alarm
STS	YELLOW	OFF	Device in RUN modality
		BLINK	Device in INIT modality
I n	RED	ON	Digital Inputs High Level (1)
		OFF	Digital Inputs Low Level (0)
O n	RED	ON	Digital Outputs High Level (1)
		OFF	Digital Outputs Low Level (0)

### 7 User Guide – MODBUS TCP/IP

All of the data shared by a module communicating via Modbus TCP/IP protocol are mapped in tables at defined addresses.

Each data can be of two types:

- "REGISTER", 2 bytes (word of 16 bits) that can be associated with analogue input or output, variables, set-point, etc...
- "COIL", 1 single bit that can be associated with digital input or output or to a logic state.

A register can contain the image (mirror) of more coils; for example, each of the 16 digital inputs of a module can be read or written as a single bit by addressing the coil related to each input. Alternatively, the 16 bits can be read or written as a single word addressing the associated register where each bit corresponds to a coil. In the Modbus protocol, registers and coils are divided as per the following groups of addresses:

0xxxx and 1xxxx = Coils (bit)

3xxxx and 4xxxx = Registers (word)

When read and write functions are performed, use the tables indicated below to address the registers. It is possible to access the internal registers of the module by direct command Modbus TCP/IP or by the integrated web server.

### 8 Supported Modbus Function Codes

Function	Description
01	Read Coil Status (0xxxx)
02	Read Inputs Status (1xxxx)
03	Read Holding Registers (4xxxx)
04	Read Inputs Registers (3xxxx)
05	Force Single Coil
06	Preset Single Register
15 (0F)	Force Multiple Coil
16 (10)	Preset Multiple Registers

### 9 Coil Table

(*)Coil (Hex)	(*)Coil (Dec)	Description	Access
0x0092	00146	Watch-dog Enable	R/W
0x0093	00147	Watch-dog Event	R/W
0x0094	00148	Power-Up Event	R/W
0x01E9	00489	Output #0	R/W
0x01EA	00490	Output #1	R/W
0x01EB	00491	Output #2	R/W
0x01EC	00492	Output #3	R/W
0x01ED	00493	Output #4	R/W
0x01EE	00494	Output #5	R/W
0x01EF	00495	Output #6	R/W
0x01F0	00496	Output #7	R/W
0x01F9	00505	Input #0	RO
0x01FA	00506	Input #1	RO
0x01FB	00507	Input #2	RO
0x01FC	00508	Input #3	RO
0x01FD	00509	Input #4	RO
0x01FE	00510	Input #5	RO
0x01FF	00511	Input #6	RO
0x0200	00512	Input #7	RO
0x0209	00521	Latch rise #0	R/W
0x020A	00522	Latch rise #1	R/W
0x020B	00523	Latch rise #2	R/W
0x020C	00524	Latch rise #3	R/W
0x020D	00525	Latch rise #4	R/W
0x020E	00526	Latch rise #5	R/W
0x020F	00527	Latch rise #6	R/W
0x0210	00528	Latch rise #7	R/W
0x0219	00537	Latch drop #0	R/W
0x021A	00538	Latch drop #1	R/W
0x021B	00539	Latch drop #2	R/W
0x021C	00540	Latch drop #3	R/W
0x021D	00541	Latch drop #4	R/W
0x021E	00542	Latch drop #5	R/W
0x021F	00543	Latch drop #6	R/W
0x0220	00544	Latch drop #7	R/W

#### NOTES:

For HE399 series modules, the group of data 0xxxx is the mirror of the group 1xxxx, the group of data 3xxxx is the mirror of the group 4xxxx, therefore the first register could be addressed either as 30002 (with function 04) or 40002 (with function 03).

The maximum number of coils that can be read through Modbus functions 01 and 02 is **128**. The maximum number of registers that can be read through Modbus functions 03 and 04 is **64**. The maximum number of registers that can be written by Modbus function 16 is **64**. The maximum number of coils that can be written by Modbus function 15 is **64**. See **Supported Modbus Functions Codes** above.

**10 Register Table**

Register Position (*)	Description	Access
40002	Firmware [0]	RO
40003	Firmware [1]	RO
40004	Name [0]	R/W
40005	Name [1]	R/W
40007	Node ID	R/W
40011	System Flags	R/W
40012	Power Up / Safe	R/W
40013	Watchdog timer	R/W
40031	Digital Outputs	R/W
40032	Digital Inputs	RO
40033	Digital Inputs Rise Latch	R/W
40034	Digital Inputs Fall Latch	R/W
40035	Freq. Digital Input 0	RO
40036	Freq. Digital Input 1	RO
40037	Freq. Digital Input 2	RO
40038	Freq. Digital Input 3	RO
40039	32 bit Counter Digital Input 0	R/W
40041	32 bit Counter Digital Input 1	R/W
40043	32 bit Counter Digital Input 2	R/W
40045	32 bit Counter Digital Input 3	R/W

**11 Description Modbus Registers****40002 / 40003: FIRMWARE**

Field of 2 read only registers; contains the firmware identifier provided by the manufacturer.

**40004 / 40005: NAME**

Field of 2 read/write registers (4 bytes or 4 ASCII characters) available for the user, it can contain the name of the module or an abbreviation that identifies its function inside the plant. Each one of the 4 bytes can be written by values from 0 to 255, ASCII characters included.

The default value of this field contains the identifier of the module expressed in ASCII characters.

-Default value: "930A" (ASCII).

**40007: NODE ID**

Contains the MODBUS address of the module, the decimal values allowed are from 1 to 255. This data is necessary for the correct addressing of the module into the Modbus net and must follow the IP address.

Default value: Dec: 1, Hex: 01 INIT: Dec 245, Hex: F5.

**40011: SYSTEM FLAGS**

Contains the enable bits and system events of the device. The following parameters are configurable:

**WATCHDOG ENABLE (161)**

This bit allows the enabling/disabling of the Watchdog Event

0 = Watchdog disabled

1 = Watchdog enabled

If this bit is active and the module doesn't receive commands for the time specified in the register 40013 **Watchdog Timer** the outputs of the device will be forced as a function of the settings of the register 40011 section "Safe". The Watchdog condition is signaled by the blinking PWR LED.

If this function is required it must be implemented at power-up of the module, the bit must be reset manually when the Watchdog event has occurred.

**WATCHDOG EVENT (162)**

If this bit is set to 1, this indicates that the Watchdog condition has happened

0 = Normal condition

1 = alarm condition

**POWER-UP EVENT (163)**

This bit is forced to 1 each time the module is powered-on and indicates that the module has been switched off or reset. By setting this bit to 0 and checking its state it is possible to monitor if a reset of the module has occurred.

0 = reset not occurred

1 = reset occurred.

Bit	15-13	12	11	10	9	8	7	6	5-0
Set	-	-	-	163	162	161	-	-	-

**40012: POWERUP/SAFE**

At power-on (PowerUp) and in the case of Watchdog Alarm (Safe), the state of the outputs is automatically driven to the value set in this register. Each bit corresponds to one digital output, see the function table below:

- Default value: 0

Bit	15-12	11-08	07-04	03-00
Channel	-	#3-#0	-	#3-#0
Value	Power Up		Safe	

**40013: WATCHDOG TIMER**

Contains the value of the WatchDog timer, expressed in intervals of 1 second.

If the WatchDog is enabled and the module doesn't receive commands in a time lower or equal to the value of the one expressed in this register the WatchDog will be activated (see description register **System Flags**).

-Default value: 10 (10 sec.)

**40031: DIGITAL OUTPUTS**

This register allows one to command directly the state of the output transistor (0 = OFF; 1 = ON). It is also possible to read and drive the outputs using the specific functions of the read and force coils (01-02-05-15), referring to the section in the coils table of which this register is a mirror. It is possible to read all the bits in this register at the same time without implementing the coils specific functions.

Bit	15	14	13	12	11	10	09	08	07	06	05	04	03	02	01	00
Output	-	-	-	-	-	-	-	-	-	-	-	-	#3	#2	#1	#0

**40032: DIGITAL INPUTS**

This register shows the condition of the digital inputs (0 = OFF; 1 = ON).

The same inputs can also be read using the specific functions of the reading coils (01-02) referring to the section in the coils table of which this register is a mirror. It is possible to read all the bits in this register at the same time without implementing the coils specific functions.

Bit	15	14	13	12	11	10	09	08	07	06	05	04	03	02	01	00
Input	-	-	-	-	-	-	-	-	#7	#6	#5	#4	#3	#2	#1	#0

**40033: DIGITAL INPUTS RISE LATCH**

The bits in this register are used to indicate the condition of the raised edge (change of event from state 0 to the state 1) of each digital input. The latch event shows the single change of state and is not updated by the system. In the event of this, it is necessary to monitor this parameter continuously, the single bit or the group of bits must be written to 0 after the rising edge occurs. It is also possible to read and drive the bits using the specific functions of the read and force coils (01-02-05-15) referring to the section in the coils table of which this register is a mirror. It is possible to read all the bits in this register at the same time without implementing the coils specific functions.

Bit	15	14	13	12	11	10	09	08	07	06	05	04	03	02	01	00
Latch	-	-	-	-	-	-	-	-	#7	#6	#5	#4	#3	#2	#1	#0

**40034: DIGITAL INPUTS FALL LATCH**

The bits in this register are used to indicate the condition of the fall edge (event of change of level from the state 1 to the state 0) of each digital input. The latch event shows the single change of state and is not updated by the system. In the event of this, it is necessary to monitor this parameter continuously, the single bit or the group of bits must be written to 0 after the falling edge occurs. It is also possible to read and drive the bits using the specific functions of the read and force coils (01-02-05-15) referring to the section in the coils table of

which this register is a mirror. It is possible to read all the bits in this register at the same time without implementing the coils specific functions.

Bit	15	14	13	12	11	10	09	08	07	06	05	04	03	02	01	00
Latch	-	-	-	-	-	-	-	-	#7	#6	#5	#4	#3	#2	#1	#0

#### **40035: FREQUENCY DIGITAL INPUT 0**

This register shows the frequency value related to the digital input channel 0. The value, expressed in 0.01Hz is a 16-bit Integer. The maximum value of measurable frequency is 300.00 Hz.

#### **40036: FREQUENCY DIGITAL INPUT 1**

This register shows the frequency value related to the digital input channel 1. The value, expressed in 0.01Hz is a 16-bit Integer. The maximum value of measurable frequency is 300.00 Hz.

#### **40037: FREQUENCY DIGITAL INPUT 2**

This register shows the frequency value related to the digital input channel 2. The value, expressed in 0.01Hz is a 16-bit Integer. The maximum value of measurable frequency is 300.00 Hz.

#### **40038: FREQUENCY DIGITAL INPUT 3**

This register shows the frequency value related to the digital input channel 3. The value, expressed in 0.01Hz is a 16-bit Integer. The maximum value of measurable frequency is 300.00 Hz.

#### **40039-40 (LO-HI): 32 BIT COUNTER DIGITAL INPUT 0**

These registers show the value of the digital counter related to the input channel 0. The value is incremented at each change of level from 0 to 1 of the input channel. The register type is an unsigned 32-bit Integer and uses 2 registers.

It is possible to reset the value by writing directly. At each power-on of the device the value is set to 0.

#### **40041-42 (LO-HI): 32 BIT COUNTER DIGITAL INPUT 1**

These registers show the value of the digital counter related to the input channel 1. The value is incremented at each change of level from 0 to 1 of the input channel. The register type is an unsigned 32-bit Integer and uses 2 registers.

It is possible to reset the value by writing directly. At each power-on of the device the value is set to 0.

#### **40043-44 (LO-HI): 32 BIT COUNTER DIGITAL INPUT 2**

These registers show the value of the digital counter related to the input channel 2. The value is incremented at each change of level from 0 to 1 of the input channel. The register type is an unsigned 32-bit Integer and uses 2 registers.

It is possible to reset the value by writing directly. At each power-on of the device the value is set to 0.

#### **40045-46 (LO-HI): 32 BIT COUNTER DIGITAL INPUT 3**

These registers show the value of the digital counter related to the input channel 3. The value is incremented at each change of level from 0 to 1 of the input channel. The register type is an unsigned 32-bit Integer and uses 2 registers.

It is possible to reset the value by writing directly. At each power-on of the device the value is set to 0.

## 12 Procedure

### **USE OF THE FUNCTION "INIT" (\*)**

All HE399 series modules are equipped with INIT mode. This procedure allows access to the module through the default parameters in order to proceed with its configuration:

IP Address: XXX.XXX.XXX.XXX (assigned by DHCP if enabled) 192.168.1.174 (DHCP disabled, indicates that the IP is not in use) Modbus address: 245  
Using these parameters, it is possible to access the module in INIT modality to set and check the configuration.

To work in INIT use the following procedure:

- Switch-off the module.
- Connect the terminal INIT to terminal -V.
- Power-on the module.
- Connect to the module using of the default parameters above.
- When the user is finished working in INIT.

- Switch-off the module.
- Disconnect INIT.
- Power-on the module and connect to it using the known parameters or by those set in INIT mode.

### **WATCHDOG**

The HE399 series is equipped with a Watchdog timer, if enabled, activates an alarm each time that communication is lost between the module and the master for a period time greater than the programmed one. In the alarm condition the values of the outputs are automatically set as defined in the register. **PowerUp/Safe**, this is the condition to which the outputs must be set to avoid damage to the system in the case of a fault occurring. The value set cannot be the same as the value of the outputs before the reset. After the reset a command has to be resent to set the output port. During this alarm condition the green LED on the front of the device blinks and the **Watchdog Event** coil is forced to 1. To exit from the alarm condition reset the **Watchdog Event** coil, the LED will stop blinking and it will be possible to command the outputs.

### **FUNCTION BUTTON "P"**

To restore the default parameters of the module, with the module powered on and not in the INIT condition, push and hold button "P", located on the front, for at least 5 seconds.

The green PWR LED will switch-off, the yellow STS LED will become orange, and the module will reset.

When the reset has finished, both the LEDs will return to the default condition and the following parameters will be loaded:

#### **Ethernet:**

- IP Address: 192.168.1.100
- Subnet Mask: 255.255.255.0
- Gateway Mask: 192.168.1.1

**Username:** Fact\_user

**Password:** Fact\_pwd

#### **Modbus:**

Address: 1

## 13 Installation / safety

**Warning:** Remove power from the OCS controller, CAN port, and any peripheral equipment connected to this local system before adding or replacing this or any module.

- All applicable codes and standards should be followed in the installation of this product.
- Shielded, twisted-pair wiring should be used for best performance.
- Shields may be terminated at the module terminal strip.
- In severe applications, shields should be tied directly to the ground block within the panel.
- Use the following wire type or equivalent: Belden 8441.

For detailed installation and a [handy checklist](#) that covers panel box layout requirements and minimum clearances, refer to the hardware manual of the controller you are using.

When found on the product, the following symbols specify:



**Warning:** Electrical Shock Hazard.



**Warning:** Consult user documentation.

## 14 Technical support

Technical Support at the following locations:

#### **North America:**

Tel: 317 916-4274  
Fax: 317 639-4279  
Web: [www.hornerautomation.com](http://www.hornerautomation.com)  
Email: [techsppt@heapg.com](mailto:techsppt@heapg.com)

#### **Europe:**

Tel: +353-21-4321266  
Fax: +353-21-4321826  
Web: <http://www.horner-apg.com>  
Email: [tech.support@horner-apg.com](mailto:tech.support@horner-apg.com)

No part of this publication may be reproduced without the prior agreement and written permission of Horner APG, Inc. Information in this document is subject to change without notice.