



SmartMod+ Analogue Input Module HE399THM100

4 Isolated Input Channels in pairs for
mV and Tc



1 Specifications

	Min	Max		
Input Voltage	-250mV	+250mV	Input Accuracy	≥0.05%f.s. and ±5µV
Thermocouple J K R S B E T N	-210 °C	+1200 °C	Linearity	mV ±0.1% f.s. Tc ±0.2% f.s.
	-210 °C	+1372 °C	Thermal Drift	Full Scale ±0.005%/°C
	-50 °C	+1767 °C		
	-50 °C	+1767 °C	CJC error	±1°C
	+400 °C	+1825 °C	Thermal Drift CJC	Full Scale ±0.02%/°C
	-210 °C	+1000 °C		
-210 °C	+400 °C	Sampling time (4 ch)	150ms	
-210 °C	+1300 °C	Lead wire resistance influence	Full Scale ±0.02%/°C	
Low High	0 Ω	500 Ω	Mounting	DIN Rail standard EN-50022
Input Impedance	≥1 MΩ		Protocol	Modbus TCP
Relative Humidity	0 to 90% Non-condensing		Number of socket	Up to 16
Network Interface	Ethernet 10/100 Base-T		Storage Temp.	-40 – 85 °C
Max Cable Length	100 meters		Weight	~160g
Operating Temp.	-10° to 60 °C		Connections	Ethernet, RJ45, Removable screw-terminals
External Power Supply Voltage	14-30Vdc		Warm up time	3 min
Power Consumption	Standby – 60 mA tip@24Vdc Operative – 75mA max@24Vdc Operative – 115 mA@14Vdc		Max. Data Transmission Baud Rate	115.2 Kbps
Reverse Polarity Protection	60 Vdc max		Max. Distance	1200m
Isolation	1500 Vac, 50Hz, 1 min			
CE Compliance	Immunity EN 61000-6-2 Emission EN 61000-6-4			

Mechanical Dimensions (mm)

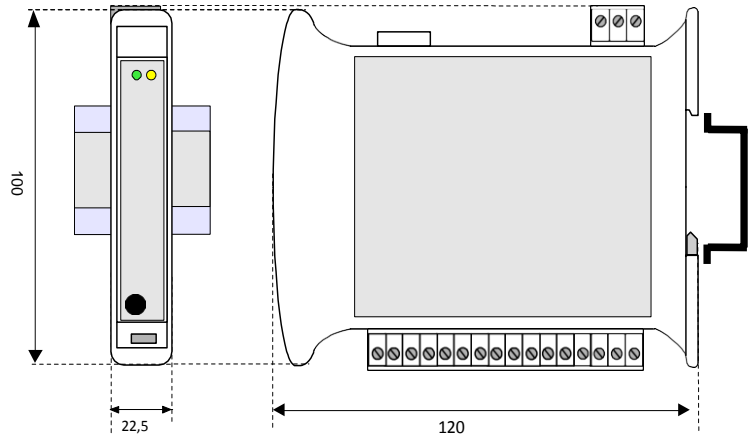

Note: Number of I/O terminal connections varies from model to model

CONNECTIONS

Analogue Inputs

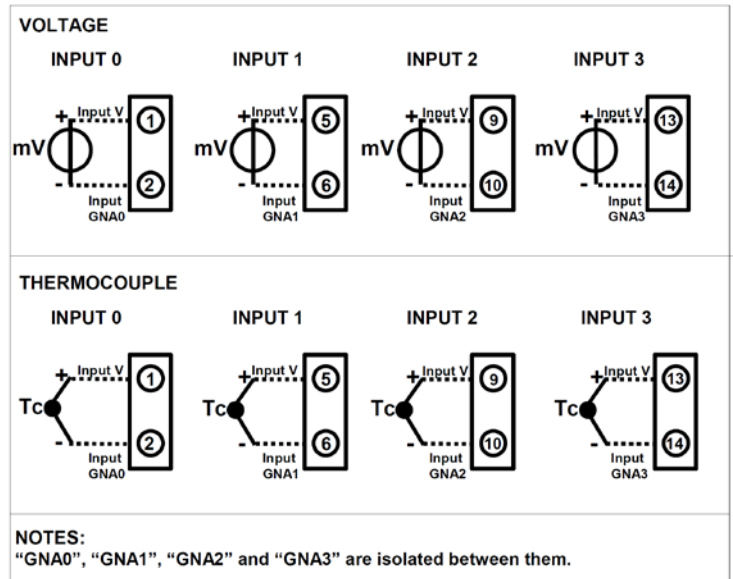

2 Connections

Power Supply

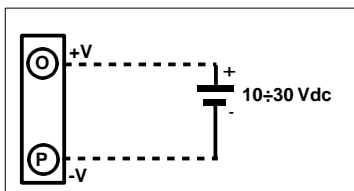

INIT

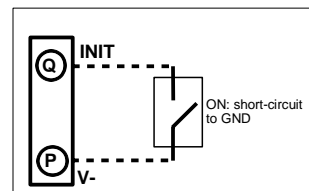

3 Communication Protocols

The module is designed to work with the MODBUS TCP/IP protocol. The Ethernet interface allows the values of the modules internal registers to be written and read in real time, and allows the direct interface of HE399 series modules to all Horner Ethernet based X-Series controllers.

4 User Instructions

Before installing this module, please read the **Installation Instructions** section carefully. To configure the module using the INIT mode: Connect the terminal INIT to the terminal -V, at power-on the module will automatically set to the configuration set-up. Connect the power supply, serial bus, inputs and outputs as shown in the **Wiring** section. The LEDs state depends on the working condition of the module, see the **LED Indicator** section to verify the modules working state. To perform configuration and calibration operations, read the instructions below.

To simplify handling or replacing the module, it is possible to remove the wired terminals when the module is powered on.

5 Installation Instructions

Attach the HE399THM100 to DIN rails in the vertical position. For optimum operation follow these instructions:

When the modules are installed side by side and - If the panel temperature exceeds 45°C and power supply voltage is 10 VDC - **it may be necessary to separate them by >5 mm:**

Make sure that there is sufficient air flow around the module, avoid placing near cable routing or other objects that can obstruct the ventilation slits. Additionally, avoid mounting modules above appliances that generate heat. Ideally, they should be placed in the lower part of the panel. Install the module in a location without vibration.

It is also recommended to avoid routing conductors near power signal cables (motors, induction ovens, inverters etc...) and to use shielded cables for connecting signals.

6 LED Indicator

LED	COLOUR	STATE	DESCRIPTION
PWR	GREEN	ON	Device powered
		OFF	Device not powered
		BLINK	Watchdog alarm
STS	YELLOW	OFF	Device in RUN mode
		BLINK	Device in INIT mode

The LED's are located on the front of the model.

7 User Guide – MODBUS TCP/IP

All of the data shared by a module communicating via Modbus TCP/IP protocol are mapped in tables at defined addresses.

Each data can be of two types:

- "REGISTER", 2 bytes (word of 16 bits) that can be associated with analogue input or output, variables, set-point, etc...
- "COIL", 1 single bit that can be associated with digital input or output or to a logic state.

A register can contain the image (mirror) of more coils; for example, each of the 16 digital inputs of a module can be read or written as a single bit by addressing the coil related to each input. Alternatively, the 16 bits can be read or written as a single word addressing the associated register where each bit corresponds to a coil. In the Modbus protocol, registers and coils are divided as per the following groups of addresses:

0xxxx and 1xxxx = Coils (bit)

3xxxx and 4xxxx = Registers (word)

When read and write functions are performed, use the tables indicated below to address the registers. It is possible to access the internal registers of the module by direct command Modbus TCP/IP or by the integrated web server.

8 Supported Modbus Function Codes

Function	Description
01	Read Coil Status (0xxxx)
02	Read Inputs Status (1xxxx)
03	Read Holding Registers (4xxxx)
04	Read Inputs Registers (3xxxx)
05	Force Single Coil
06	Preset Single Register
15 (0F)	Force Multiple Coil
16 (10)	Preset Multiple Registers

9 Coil Table

(*)Coil (Hex)	(*)Coil (Dec)	Description	Access
0x00A1	00161	Watch-dog Enable	R/W
0x00A2	00162	Watch-dog Event	R/W
0x00A3	00163	Power-Up Event	R/W

NOTES:

For HE399 series modules, the group of data 0xxxx is the mirror of the group 1xxxx, the group of data 3xxxx is the mirror of the group 4xxxx, therefore the first register could be addressed either as 30002 (with function 04) or 40002 (with function 03).

The maximum number of coils that can be read through Modbus functions 01 and 02 is **128**. The maximum number of registers that can be read through Modbus functions 03 and 04 is **64**. The maximum number of registers that can be written by Modbus function 16 is **64**. The maximum number of coils that can be written by Modbus function 15 is **64**. See **Supported Modbus Functions Codes** above.

10 Register Table

Position Register	Description	Access
40002	Firmware [0]	RO
40003	Firmware [1]	RO
40004	Name [0]	R/W
40005	Name [1]	R/W
40007	Node ID	R/W
40011	System Flags	R/W
40013	Watchdog timer	R/W
40031	Input type Ch 0	R/W
40032	Input type Ch 1	R/W
40033	Input type Ch 2	R/W
40034	Input type Ch 3	R/W
40036	Break status	RO
40041	Analogue Input (0) - Ch0	RO
40042	Analogue Input (1) - Ch1	RO
40043	Analogue Input (2) - Ch2	RO
40044	Analogue Input (3) - Ch3	RO

11 Description Modbus Registers

40002 / 40003: FIRMWARE

Field of 2 read only registers; contains the firmware identifier provided by the manufacturer.

40004 / 40005: NAME

Field of 2 read/write registers (4 bytes or 4 ASCII characters) available for the user, it can contain the name of the module or an abbreviation that identifies its function inside the plant. Each one of the 4 bytes can be written by values from 0 to 255, ASCII characters included.

The default value of this field contains the identifier of the module expressed in ASCII characters.

-Default value: "9501" (ASCII).

40007: NODE ID

Contains the MODBUS address of the module, the decimal values allowed are from 1 to 255. This data is necessary for the correct addressing of the module into the Modbus net and must follow the IP address.

Default value: Dec: 1, Hex: 01 INIT: Dec 245, Hex: F5.

40011: SYSTEM FLAGS

Contains the enable bits and system events of the device. The following parameters are configurable:

WATCHDOG ENABLE (161)

This bit allows the enabling/disabling of the Watchdog Event

0 = Watchdog disabled

1 = Watchdog enabled

If this bit is active and the module doesn't receive commands for the time specified in the register 40013 **Watchdog Timer** the outputs of the device will be forced as a function of the settings of the register 40011 section "Safe". The Watchdog condition is signaled by the blinking PWR LED.

If this function is required it must be implemented at power-up of the module, the bit must be reset manually when the Watchdog event has occurred.

WATCHDOG EVENT (162)

If this bit is set to 1, this indicates that the Watchdog condition has happened

0 = Normal condition

1 = alarm condition

POWER-UP EVENT (163)

This bit is forced to 1 each time the module is powered-on and indicates that the module has been switched off or reset. By setting this bit to 0 and checking its state it is possible to monitor if a reset of the module has occurred.

0 = reset not occurred

1 = reset occurred.

Bit	15-13	12	11	10	9	8	7	6	5-0
Set	-	-	-	163	162	161	-	-	-

40013: WATCHDOG TIMER

Contains the value of the WatchDog timer, expressed in intervals of 1 second.

If the WatchDog is enabled and the module doesn't receive commands in a time lower or equal to the value of the one expressed in this register the WatchDog will be activated (see description register **System Flags**).

-Default value: 10 (10 sec.)

40031: INPUT TYPE Ch 0

This register shows the input type that is configured in relation to the type of sensor connected. The Input Type table shows the types of sensors that can be connected to the input with the corresponding value to be written on the low part of the register for the configuration of the input type.

Default manufacturer: Tc K (05 Hex)

Bit	15-08	07-00
Descr.	-	Input Type #0

40032: INPUT TYPE Ch 1

This register shows the input type that is configured in relation to the type of sensor connected. The Input Type table shows the types of sensors that can be connected to the input with the corresponding value to be written on the low part of the register for the configuration of the input type.

Default manufacturer: Tc K (05 Hex)

Bit	15-08	07-00
Descr.	-	Input Type #1

40033: INPUT TYPE Ch 2

This register shows the input type that is configured in relation to the type of sensor connected. The Input Type table shows the types of sensors that can be connected to the input with the corresponding value to be written on the low part of the register for the configuration of the input type.

Default manufacturer: Tc K (05 Hex)

Bit	15-08	07-00
Descr.	-	Input Type #2

This register shows the input type that is configured in relation to the type of sensor connected. The Input Type table shows the types of sensors that can be connected to the input with the corresponding value to be written on the low part of the register for the configuration of the input type.

Default manufacturer: Tc K (05 Hex)

Bit	15-08	07-00
Descr.	-	Input Type #3

Input Type Table

Input	Value (Hex)	Value (Dec)
Disabled	00h	0
250 mV	01h	1
Tc J	04h	4
Tc K	05h	5
Tc R	06h	6
Tc S	07h	7
Tc T	08h	8
Tc B	09h	9
Tc E	0Ah	10
Tc N	0Bh	11

40036: BREAK STATUS

When the sensor connected to a channel is in the fault condition (disconnected cable or over-temperature), the bit corresponding to the channel is set to 1.

Bit	15	14	13	12	11	10	09	08	07	06	05	04	03	02	01	00
Input	-	-	-	-	-	-	-	-	-	#3	-	#2	-	#1	-	#0

40041: ANALOGUE INPUT #0**40042: ANALOGUE INPUT #1****40043: ANALOGUE INPUT #2****40044: ANALOGUE INPUT #3**

These registers return the value of each channel, converted to engineering units. The values are expressed in cents for mV input and tenths of °C for inputs in Tc.

The format is a 16-bit signed integer.

Example of reading:

Input set as **Tc**

Value read on the register: 246 → 24.6 °C

Input set as **mV**

Value read on the register: 24656 → 246.56 mV

12 Procedure**USE OF THE FUNCTION "INIT" (*)**

All HE399 series modules are equipped with INIT mode. This procedure allows access to the module through the default parameters in order to proceed with its configuration:

IP Address: XXX.XXX.XXX.XXX (assigned by DHCP if enabled) 192.168.1.174 (DHCP disabled, indicates that the IP is not in use) Modbus address: 245 Using these parameters, it is possible to access the module in INIT modality to set and check the configuration.

To work in INIT use the following procedure:

- Switch-off the module.
- Connect the terminal INIT to terminal -V.
- Power-on the module.
- Connect to the module using of the default parameters above.
- When the user is finished working in INIT.
- Switch-off the module.
- Disconnect INIT.
- Power-on the module and connect to it using the known parameters or by those set in INIT mode.

WATCHDOG

The HE399 series is equipped with a Watchdog timer, if enabled, activates an alarm each time that communication is lost between the module and the master for a period time greater than the programmed one. In the alarm condition the values of the outputs are automatically set as defined in the register. **PowerUp/Safe**, this is the condition to which the outputs must be set to avoid damage to the system in the case of a fault occurring. The value set cannot be the same as the value of the outputs before the reset. After the reset a command has to be resent to set the output port.

During this alarm condition the green LED on the front of the device blinks and the **Watchdog Event** coil is forced to 1. To exit from the alarm condition reset the **Watchdog Event** coil, the LED will stop blinking and it will be possible to command the outputs.

FUNCTION BUTTON "P"

To restore the default parameters of the module, with the module powered on and not in the INIT condition, push and hold button "P", located on the front, for at least 5 seconds.

The green PWR LED will switch-off, the yellow STS LED will become orange, and the module will reset.

When the reset has finished, both the LEDs will return to the default condition and the following parameters will be loaded:

Ethernet:

- IP Address: 192.168.1.100
- Subnet Mask: 255.255.255.0
- Gateway Mask: 192.168.1.1

Username: Fact_user

Password: Fact_pwd

Modbus:

Address: 1

13 Installation / Safety

Warning: Remove power from the OCS controller, CAN port, and any peripheral equipment connected to this local system before adding or replacing this or any module.

- All applicable codes and standards should be followed in the installation of this product.
- Shielded, twisted-pair wiring should be used for best performance.
- Shields may be terminated at the module terminal strip.
- In severe applications, shields should be tied directly to the ground block within the panel.
- Use the following wire type or equivalent: Belden 8441.

For detailed installation and a [handy checklist](#) that covers panel box layout requirements and minimum clearances, refer to the hardware manual of the controller you are using.

When found on the product, the following symbols specify:



Warning: Electrical Shock Hazard.



Warning: Consult user documentation.

14 Technical support

Technical Support at the following locations:

North America:

Tel: 317 916-4274
Fax: 317 639-4279
Web: www.hornerautomation.com
Email: techsppt@heapg.com

Europe:

Tel: +353-21-4321266
Fax: +353-21-4321826
Web: <http://www.horner-apg.com>
Email: tech.support@horner-apg.com

No part of this publication may be reproduced without the prior agreement and written permission of Horner APG, Inc. Information in this document is subject to change without notice.